



SPECIAL PURPOSE VEHICLE

<p>BRAKE & CLUTCH MASTER CYLINDER KIT 《修理包》</p>	<p>Φ14.9MM </p> <p>04472-20030-71 TOYOTA 5FD25 (C/M) TCM 4T-4.5T (HYDRAULIC) Φ14.9m/m TO-001-K</p>	<p></p> <p>04311-40010-71 TOYOTA (B/M) TO-002-K</p>	<p></p> <p>04471-10052-71 TOYOTA 5FD15 (B/M) TO-003-K</p>
<p>Φ13.4MM </p> <p>04472-20030-71 TOYOTA 5FD 2.5T (C/M) Φ13.4m/m TO-004-K</p>	<p>Φ15.5MM </p> <p>04311-10060-71 TOYOTA 5FD40 (C/M) TCM 4T (Z-6) Φ15.5m/m TO-005-K</p>	<p></p> <p>04471-10024 TOYOTA D700 (B/M) (JAPAN) 5/8" TO-006-K</p>	<p>Φ18.9MM </p> <p>TOYOTA 6FD25 (B/M) Φ18.9m/m TO-007-K</p>
<p>Φ17.9MM </p> <p>04311-20050-71 (kit) TOYOTA 5F 2.5-3T (B/M) Φ17.9m/m TO-008-K</p>	<p></p> <p>04311-20070-71 TOYOTA 3FD (HYDRAULIC) 5/8" TO-301-K</p>	<p></p> <p>901196850 YALE 2.5T 寸進修理包 YA-01K</p>	



SPECIAL PURPOSE VEHICLE

**BOOSTER
AIR TANK**
《真空剎車補助器》



91846-14600
MITSUBISHI FD45 19C/19B
AIRP-001



92047-05100
MITSUBISHI FD35 19B
--- S6S F20C F20B FD60-70
AIRP-002



3FD-38-21170
KOMATSU FD50-70 7S
AIRP-002ASSY



91351-12100
MITSUBISHI F18B FD20/25
離合器補助器 AIRP-003



91851-22600
MITSUBISHI 19B FD40
離合器補助器 AIRP-004



92348-26400
MITSUBISHI
-- FD80-150A FD100N-160N
AIRP-005



290A5-47362
TCM FD115-160S-3
AIRP-006



47230-43630-71
TOYOTA 2TD15-25
AIRP-007

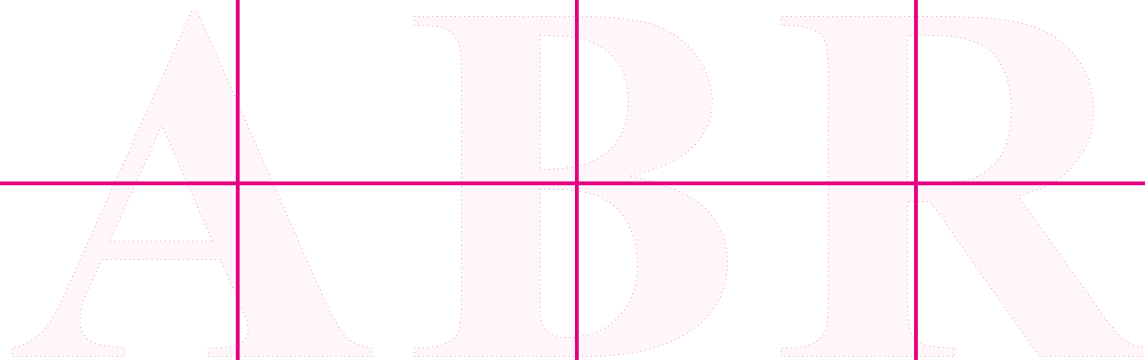



SPECIAL PURPOSE VEHICLE

<p>UNIVERSAL JOINT (DRIVE SHAFT) (PROPELLER SHAFT) 《傳動軸》</p>	 <p>91171-00010 MITSUBISHI 2T S4E G10T 160MM UJ-1001</p>	 <p>91871-10011 MITSUBISHI 3.5T G13T 160MM UJ-1001-1</p>	 <p>91171-02010 MITSUBISHI 1.5T G10T 228MM UJ-1002</p>
 <p>UJ-1003-B 91271-03200 UJ-1003-C 58671-20700 91271-07700 UJ-1003-A</p> <p>91571-20020 MITSUBISHI 4T S6S G13T 228MM UJ-1003</p>	 <p>9147844-01 YALE 2.5T/3T UJ-1004</p> <p>900-715-300 UJ-1004-1</p>	 <p>11T *47m/m</p> <p>1451966 YALE 2.5T COUPLING UJ-1004-11T</p>	 <p>13T *39m/m</p> <p>0034187 YALE 3T COUPLING UJ-1004-13T</p>
 <p>11T</p> <p>YALE 2.5T G11T UJ-1004-3-11T</p>	 <p>13T</p> <p>YALE 3T G13T UJ-1004-4-13T</p>	 <p>91871-00021 MITSUBISHI 4T S6S G13T 185MM UJ-1005</p>	 <p>91871-10021 MITSUBISHI 4T S6E G13T 200MM UJ-1006</p>
 <p>91271-00010 1.5T(S4Q2 -98後) MITSUBISHI 4T S6E G10T 200MM UJ-1006-1</p>	 <p>20T</p> <p>185m/m</p> <p>67310-32880-71 1992前 TOYOTA 5F(4T) 11Z UJ-1007</p>	 <p>225m/m</p> <p>91571-00050 MITSUBISHI S4S G13T UJ-1008</p>	 <p>175m/m</p> <p>25957-20201 TCM 4T(Z-2) G15T UJ-1009</p>
 <p>175m/m</p> <p>24357-20201 TCM 4T(Z-6) G13T UJ-1010</p>	 <p>外牙</p> <p>224W7-22012 TCM 4T(Z-7)/5T G18T UJ-1011</p>	 <p>外牙</p> <p>224W7-22011(old) TCM 4T(Z-7) G13T UJ-1012</p>	 <p>9187974-00 YALE 4T HYSTER 4T UJ-1013</p>











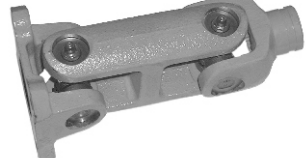

SPECIAL PURPOSE VEHICLE

<p>UNIVERSAL JOINT (DRIVE SHAFT) (PROPELLER SHAFT) 《傳動軸》</p>	 <p>30 m/m</p> <p>YALE 3.5T (老車) (四孔有牙) UJ-1013-1</p>	 <p>34 m/m</p> <p>150 m/m</p> <p>67310-32080-71 TOYOTA 3FD(3T) 13齒 UJ-1014</p>	 <p>38 m/m</p> <p>150m/m</p> <p>(底座有孔) 67310-U2100-71 TOYOTA 3FD(3T) HOLE ON THE BOTTOM 內13齒 UJ-1014-1</p>
 <p>四角</p> <p>BOBCAT 643 / 725 16T×148MM 內16齒 UJ-1015</p>	 <p>圓形</p> <p>鏟土機 16T×148MM 內16齒 UJ-1015-1</p>	 <p>67310-31700-71 TOYOTA 6FD40 12Z/13Z 195MM UJ-1016</p>	 <p>67310-30511-71 TOYOTA 7FD40 14Z 165MM UJ-1016-3</p>
 <p>67345-32881-71 TOYOTA 5/6/7FD40 PLATE JOINT YOKE SET UJ-1016-4</p>	 <p>92001-01010 MITSUBISHI S6S 3T-5T/7T 200MM G16T UJ-1017</p>	 <p>91371-20020 MITSUBISHI 1.5T G10T MITSUBISHI S4S 自排車 185MM UJ-1018</p>	 <p>YALE 5T(new) UJ-1019</p>
 <p>180m/m</p> <p>201C3-82081 TCM 4T(Z-8) G13T (T9前期) UJ-1020</p>	 <p>175m/m</p> <p>TCM 4.5T/5T(T-9) G13T 175MM UJ-1020-1</p>	 <p>3EC-01-32710 KOMATSU 3.5T/4T G13T 220MM UJ-1021</p>	 <p>91871-30040 MITSUBISHI 3.5T/4.5T 290MM G13T UJ-1022</p>
 <p>MITSUBISHI 1.5T G10T 290MM UJ-1022-1</p>	 <p>92001-10090 MITSUBISHI FB20 FD60-70 360MM UJ-1023</p>	 <p>92001-11040 MITSUBISHI FC20 F32B FD60-90 335MM UJ-1023-1</p>	 <p>TCM 4T(Z-2) LOWER (下) UJ-1024</p>

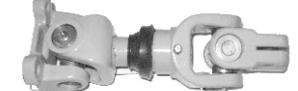

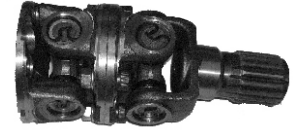









SPECIAL PURPOSE VEHICLE

<p>UNIVERSAL JOINT (DRIVE SHAFT) (PROPELLER SHAFT) 《傳動軸》</p>	 TCM 4T(Z-2) UPPER (上) UJ-1024-1	 37200-51H00 NISSAN FD40 G14T 255MM UJ-1025	 12381-L6001 NISSAN 3.5T~4.5T 13T 舊車300MM UJ-1025-2
 92201-10010 MITSUBISHI 4T S6S 270MM UJ-1026	 ↑ 四角 ↑ 圓座 67310-32881-71 1992後 TOYOTA 5FD45 UJ-1027	 37220-43630-71 TOYOTA 2TD15-25 276MM UJ-1028	 91871-10050 MITSUBISHI 3.5T-4T G13T NISSAN 5T 175MM UJ-1029
 91571-10010 MITSUBISHI 1.5T G10T (汽油車)275MM UJ-1030	 MITSUBISHI 2T G13T (汽油車)275MM UJ-1030-1	 91571-00070 MITSUBISHI S4S G13T GRENDIA 綠巨人 L:220MM UJ-1031	 MITSUBISHI S4S G13T GRENDIA 綠巨人 L:200MM UJ-1031-1
 250A3-30201 BOBCAT 743 TCM G16T 175MM UJ-1032	 BOBCAT TCM G16T 16T×13T×300MM UJ-1032-1	 67310-31720-71 TOYOTA GM52-6FG33-45 (汽油車)360MM UJ-1033	 91571-10040 MITSUBISHI 1.5T G10T 240MM UJ-1034
 67310-31630-71 TOYOTA 3FD60-80 OIL PUMP 295MM UJ-1035	 16齒 TOYOTA 3FD100 OIL PUMP 330MM UJ-1036	 A213160B DAEWOO 2.5T 16T×220MM UJ-1037	 KOMATSU 2S 6BB1鏟土機 16T×225MM UJ-1038





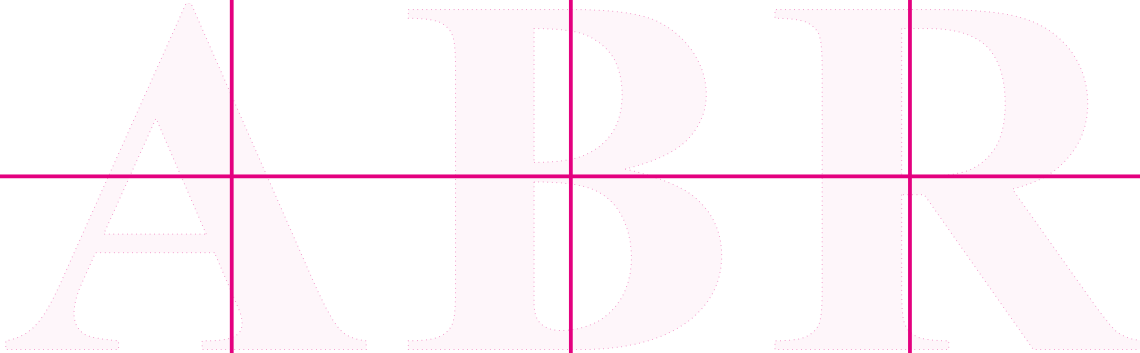

SPECIAL PURPOSE VEHICLE

<p>UNIVERSAL JOINT (DRIVE SHAFT) (PROPELLER SHAFT) 《傳動軸》</p>	 <p>1467824 HYSTER <i>11T×200MM</i></p> <p>UJ-1039</p>	 <p>1467826 HYSTER <i>11T×280MM</i></p> <p>UJ-1040</p>	 <p>243C7-22111 TCM FD35-45 T9/C9 <i>13T×305MM</i></p> <p>UJ-1041</p>
 <p>243C7-22111 TCM FD35-45 T9/C9 <i>13T×300MM</i></p> <p>UJ-1041-1</p>	 <p>3EC-20-51210 TCM FD50~80 (Z-8) 變速箱傳動軸</p> <p>UJ-1042</p>	 <p>3FD-02-32210 TCM FD50~80 (Z-8) 傳動軸 (YOKE)</p> <p>UJ-1042-H</p>	 <p>16310-N3190-71 TOYOTA 8FD35-50N 14Z 皮帶盤驅動總成 (日本十字) <i>18T×290MM</i></p> <p>UJ-1043</p>
 <p>16310-N3170-71 TOYOTA 8FD/FG35-80 <i>18T×310MM</i> (日本十字) 汽油車</p> <p>UJ-1044</p>	 <p>3EC-20-51210 KOMATSU FD35-A50 10S</p> <p>UJ-1045</p>	 <p>3FD-02-32210 KOMATSU FD60-80 10S</p> <p>UJ-1046</p>	<p>YALE/HYSTER GP50-60MX FD20-30</p> <p>UJ-1047</p>
			



SPECIAL PURPOSE VEHICLE

<p>PUMP SEAT 《邦浦座》</p>	<p>BEARING 6008×2</p>  <p>16212-32881-71 TOYOTA 5FD40 PUMP SEAT UJ-2007</p>	 <p>TOYOTA 5FD40 RUBBER CUSHION BOLT&NUT UJ-2007-1</p>	 <p>67211-30510-71 TOYOTA 7FD40 1998/12~1999/11 PUMP SEAT UJ-2008</p>
 <p>67201-30511-71 TOYOTA 7FD40 1999/11~2007/11 PUMP SEAT UJ-2009</p>	 <p>67231-30510-71 BUSH FOR PUMP SEAT UJ-2009-1</p>	 <p>16311-36761-71 TOYOTA 8FD40 UJ-2010</p>	



SPECIAL PURPOSE VEHICLE

CROSS / SPIDER 《十字軸承》

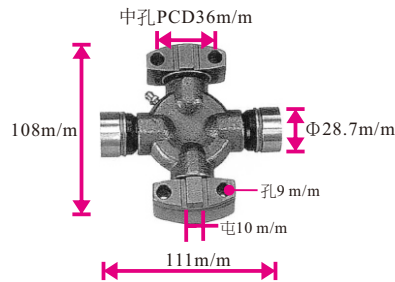

37201-23000
TCM FD25 T3
TOYOTA 5/6/7FD25
KOMATSU 鏟土機
GUKO-4C (GUT-26)

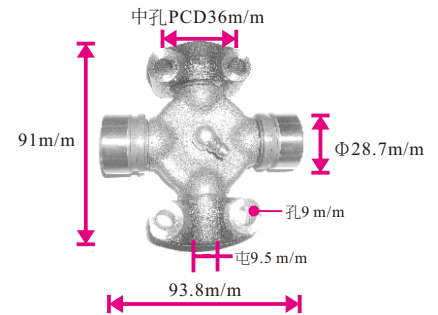

37201-26600-71
TOYOTA 8FD25
GUKO-8F

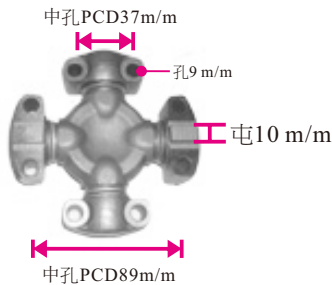

TCM 鏟土機
TOYOTA 四面四角
109m/m
G5-4143

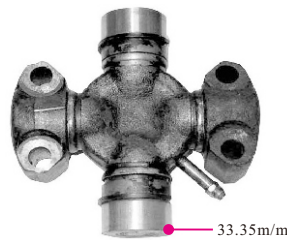

37112-33900-71
TOYOTA 5FD60
33.35x115.6x118 m/m
GU-554(G5-5015X)

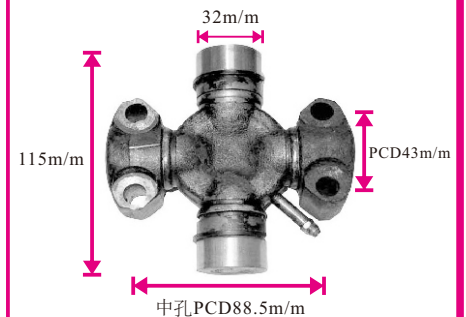

37101-33900-71
TOYOTA 5/6FD60/70
32x83.9x115 m/m
GU-555

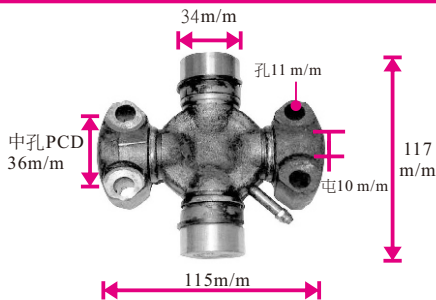

37201-30510-71
TOYOTA 6/7FD40
MITSUBISHI S4S FD30 (紫) / S6S
34x115x117 m/m
G5-5015X-1



37101-20170-71
JOINT/SHAFT 2/3FD60
33.35x115.6 m/m
GU-5000(C5-5109X)

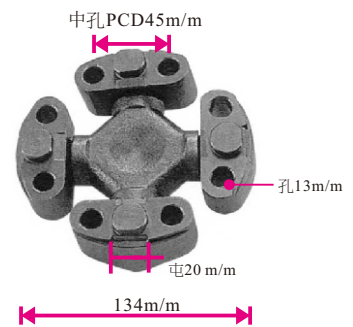

25073-30299
TCM FD35
GUTC-1

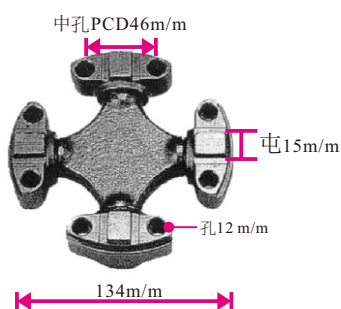

24023-30301
TCM FD35
GUTC-2

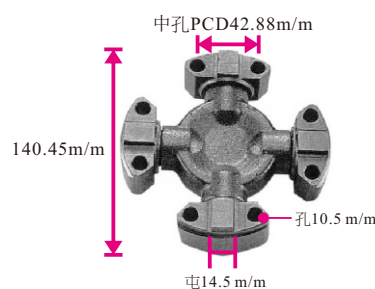

四邊孔無牙 42.88x140.45m/m
TCM FD60/100/125/150 Z-6
G5-6128(GUKO-6C)

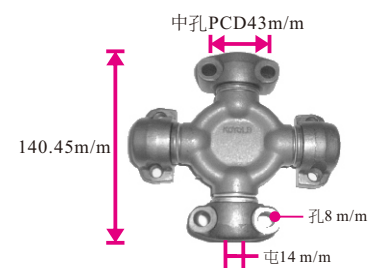

兩邊牙,兩邊孔
TCM FD50/60 Z-7
140.45m/m
C5-6102X



SPECIAL PURPOSE VEHICLE

CROSS / SPIDER 《十字軸承》

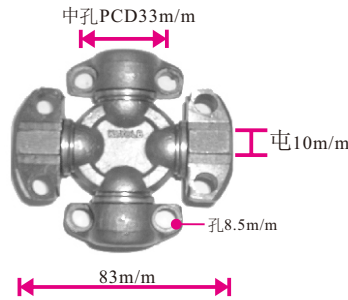

DAEWOO Fd25
TCM 725/743
BOB CAT
33.34x79m/m
四邊孔無牙
G5-2117X(GUKO-1)
(GUKO-2)

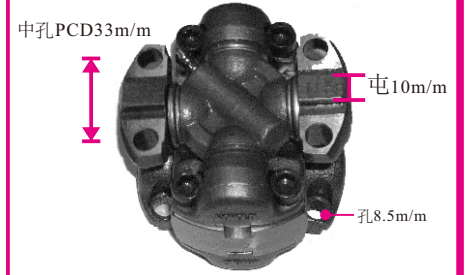

TCM SHOVELLER (鏟土機)
(四孔無牙)
GUKO-3

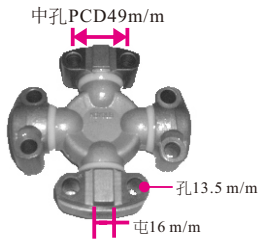

290A3-37002
TCM FD250
KOMATSU SHOVELLER (鏟土機)
49.2x148.4x16m/m
Φ14m/m
G5-7126

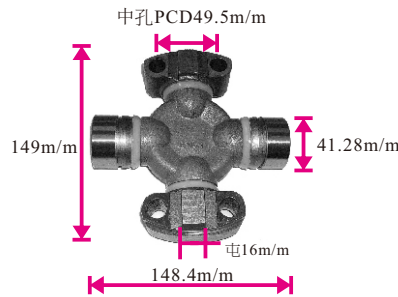

TCM FD180
KOMATSU FD85(3型)
49.5x148.4x16m/m
Φ14x41.28(圓)
378(AE7999)



KOMATSU 鏟土機
71.44x209.62m/m
C5-9016X

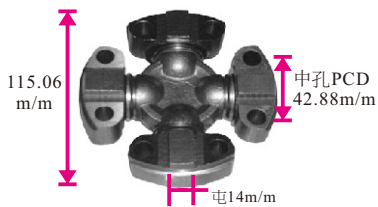

308-20-21010
KOMATSU FD50/60/80
YALE FD50/60 DAEWOO FD70
42.88x115.06m/m
川崎65鏟土機
C5-5177X (GUKO-5C)

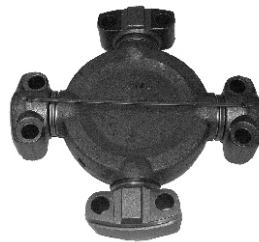

49.22x206.37m/m
重機928
G5-8105X

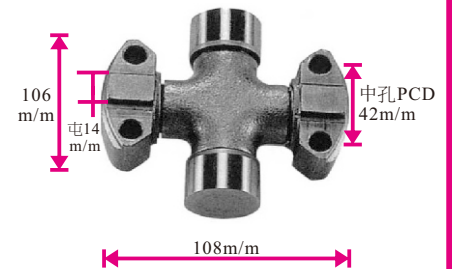

91324-08200 (old)
MITSUBISHI S4S
Φ35m/m
GUMT-1

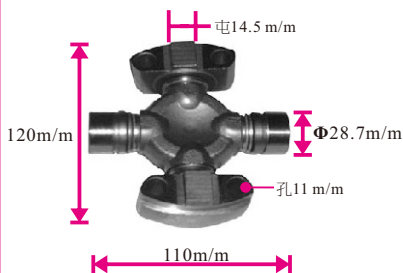

91524-10700
MITSUBISHI S4S (4G63)
Φ28.7m/m
GUMT-2













TCM FD50~FD70 Z-8
34.03x102.5x140.1/42.9m/m
C5-7203X

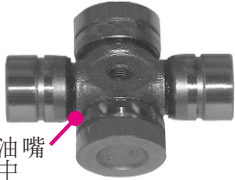

TCM FD280
71.44x165.01m/m
GUKO-8

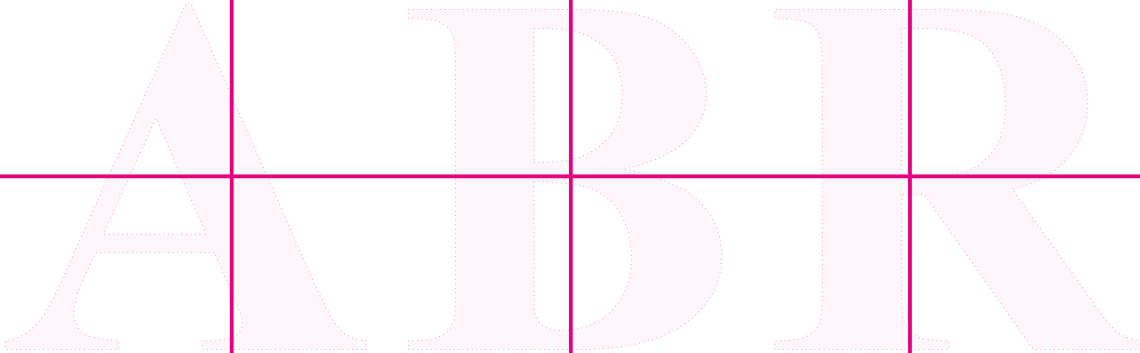

SPECIAL PURPOSE VEHICLE

<p>CROSS / SPIDER 《十字轴承》</p>	 <p>MITSUBISHI 32x110m/m GU-01</p>	 <p>黄油嘴 10 m/m</p> <p>91271-08200 22 x 54(I) m/m JOINT GU-1200</p>	 <p>黄油嘴 正中</p> <p>64371-10900 22 x 56(I) UJ-921</p>
 <p>67302-32880-71 20 x 55m/m JOINT GUD-81</p>	 <p>24357-22111 25 m/m x 40(I) JOINT GUN-27</p>	 <p>3EC-01-32620 25 x 48(I) x 69m/m GUN 27x69</p>	 <p>15594-10271 TOYOTA KOMATSU JOINT/SHAFT YOKE ST16x40</p>
 <p>TOYOTA JOINT/SHAFT 49.22x206.37m/m ST19x48</p>	 <p>67302-32880-71 TOYOTA 5FD40 20.1 x 35(I) m/m GUN-28</p>	 <p>NISSAN FD60/70 36x116m/m GUH-74</p>	 <p>TCM FD50~FD80 Z-8 變速箱軸承 38x104m/m GUM-82</p>
			







SPECIAL PURPOSE VEHICLE

<p>SHAFT ASSEMBLY 《工字鐵及總成》</p>	 <p>MITSUBISHI S4S 35m/m YOKE COUPLING H-201</p>	 <p>PCD 68 37211-23000-71 TOYOTA 5FD25 PCD68m/m YOKE COUPLING H-202</p>	 <p>PCD78m/m 37211-23600-71 TOYOTA 6FD25/7FD25 KOMATSU 16S PCD78m/m YOKE COUPLING H-203</p>
 <p>83m/m 91324-07701 MITSUBISHI S4S(4G63) 28m/m PCD83m/m H-204</p>	 <p>85m/m 37211-30510-71 TOYOTA 7FD40 34m/m H-205</p>	 <p>84m/m 37110-33900-71 TOYOTA 5FD60 33.35m/m 1997前 H-206</p>	 <p>37215-26600-71 TOYOTA 8FD25 H-207</p>
 <p>37123-20170-71 TOYOTA 3FD80 H-208</p>	 <p>KOMATSU FD15 H-209</p>	 <p>PCD 68 TCM T3 H-210</p>	 <p>YALE FD25/30 H-212</p>
 <p>TOYOTA 8FD60-80 H-214</p>	 <p>3FD-20-21130 KOMATSU FD50-80 7/8S H-215</p>	 <p>92029-00311 MITSUBISHI FD60-70 F28B F20C F20D H-216</p>	 <p>GUKO-4C 37210-23000-71 TOYOTA 5FD25 H-401</p>
 <p>GUKO-4C 37210-23600-71 TOYOTA 6/7FD25 M8x1.25m/m螺絲 H-402</p>	 <p>GUMT-1 91324-00030 MITSUBISHI S4S H-403</p>	 <p>GUMT-2 91324-00060 MITSUBISHI S4S(4G63) GRENDIA FD25 TCM T3A H-404</p>	 <p>G5-5015X-1 37210-30510-71 TOYOTA 7FD40/45 34m/m MITSUBISHI S4S FD30(96年) (紫色車種) H-405</p>



SPECIAL PURPOSE VEHICLE

<p>SHAFT ASSEMBLY 《工字鐵及總成》</p>	 <p>GU-554</p> <p>37110-33900-71 TOYOTA 5FD60 33.35m/m H-406</p>	 <p>37210-26600-71 TOYOTA 8FD25 H-407</p>	 <p>37100-20170-71 TOYOTA 3FD80 變速箱傳動軸 H-408</p>
 <p>3EA-20-51210 KOMATSU FD15 H-409</p>	 <p>12N53-32001 TCM FHD/G30 T3/T6 H-410</p>	 <p>GUKO-4C</p> <p>3EB-20-51201 KOMATSU 16S FD25/30 M8x1.0m/m螺絲 H-411</p>	 <p>GUKO-4C</p> <p>1547757 YALE/HYSTER FD25/30 YANMAR ENGINE H-412</p>
<p>NISSAN FD20-30 Y1F02 H-413</p>	 <p>37210-31040-71 TOYOTA 8FD60-80 H-414</p>	 <p>3FD-20-21100 KOMATSU FD50-80 7/8S H-415</p>	 <p>92029-00301 MITSUBISHI FD60-70 F28B F20C F20D H-416</p>
			



SPECIAL PURPOSE VEHICLE

<p>YOKE 《T型齒》</p>	<p>差速器</p>  <p>18T</p> <p>33411-23061-71 TOYOTA 5/6FD25 (FRONT) H:122MM T-40</p>	<p>變速箱</p>  <p>18T</p> <p>33412-23001-71 TOYOTA 5FD25 (REAR) LAZI 2.5T H:94.5MM T-40-1</p>	<p>差速器</p>  <p>18T</p> <p>33411-23063-71 TOYOTA 5FD30 (92年後) TOYOTA 6FD10-30 H:130MM (自排車) T-41</p>
<p>變速箱</p>  <p>18T</p> <p>33412-23600-71 TOYOTA 6FD25 圓盤 H:96MM T-41-1</p>	<p>變速箱</p>  <p>18T</p> <p>33411-23001-71 TOYOTA 5/6FD15/25 (1DZ) TCM FD25 C3 LITZ 2.5T / 3T H:113MM T-42</p>	<p>變速箱</p>  <p>22T</p> <p>12N53-52091 TCM FD25/30 C3/T3 H:117MM T-42-1</p>	<p>差速器</p>  <p>19T</p> <p>32586-23030-71 TOYOTA 5/6FD20~FD30 H:127MM (自排車) T-43</p>
<p>變速箱</p>  <p>23T</p> <p>33412-23320-71 TOYOTA 7FD25 2002/11前 H:134.5MM T-44</p>	<p>變速箱T形齒螺母</p>  <p>33418-23320-71 TOYOTA 7FD25 H:116MM T-44-1</p>	<p>差速器 40*70油封</p>  <p>18T 40MM</p> <p>41141-23320-71 TOYOTA 7FD25 排檔長桿 2000/09前 H:116MM T-45</p>	<p>變速箱</p>  <p>23T 油封外徑 40MM 48MM</p> <p>33412-23321-71 2002/11後 TOYOTA 7FD25 H:106MM T-46</p>
<p>差速器 39*69油封</p>  <p>18T 39MM</p> <p>41141-23321-71 TOYOTA 7FD25 排檔短桿 2000/9後 H:116MM T-47</p>	<p>變速箱</p>  <p>19T 油封外徑 45MM 115MM</p> <p>91324-08600 MITSUBISHI S4S (FRONT) H:120MM T-48</p>	<p>差速器</p>  <p>20T 油封外徑 55MM 115MM</p> <p>91331-20300 MITSUBISHI S4S H:111.5MM T-49</p>	<p>變速箱</p>  <p>20T 121MM</p> <p>91A24-11301 MITSUBISHI GRENDIA ----- FD15/20/25 (FRONT) H:120MM T-50</p>
<p>差速器</p>  <p>22T 總高 117.7MM</p> <p>91E31-10401 MITSUBISHI F18C F14E H:117.7MM T-50-1</p>	<p>差速器</p>  <p>20T 121MM</p> <p>91531-00600 MITSUBISHI S4S F18B H:112.5MM T-51</p>	<p>差速器</p>  <p>19T</p> <p>3EB-21-54210 KOMATSU FD25 16S H:120MM T-52</p>	<p>差速器</p>  <p>19T M8x1.0</p> <p>3EB-21-53210 KOMATSU FD30 16S 附鐵蓋 T-53</p>



SPECIAL PURPOSE VEHICLE

YOKE 《T型齒》

<p>變速箱 有孔,內牙</p>  <p>3EB-15-53250 KOMATSU FD25/30 16S H:108MM T-53-1</p>	<p>差速器</p>  <p>23T 油封外徑 45MM</p> <p>41141-30510-71 TOYOTA 7FD35~45/A50 ----- 8FD50N H:118MM T-54</p>	<p>變速箱</p>  <p>19T</p> <p>32633-26611-71 TOYOTA 8FD25-30 (自排車) H:126MM T-55</p>	
<p>差速器</p>  <p>油封外徑 39MM 18T 97MM</p> <p>41141-26600-71 TOYOTA 8FD10~30 H:98MM T-56</p>	<p>變速箱</p>  <p>油封外徑 48MM 18T 97MM</p> <p>33412-26600-71 TOYOTA 8FD30 H:107MM</p>	<p>差速器</p>  <p>19T</p> <p>32583-23330-71 TOYOTA 7FD10~30 一速2002/10前批(自排車) H:132MM T-57</p>	<p>變速箱</p>  <p>22T</p> <p>32633-23330-71 TOYOTA 7FD10~30 一速2002/10後批(自排車) H:121MM T-58</p>
<p>差速器</p>  <p>內16T</p> <p>15783-52082 TCM FD60-80 (Z-8) T-59</p>	<p>差速器</p>  <p>內14T</p> <p>16172-52711 TCM 24T/25T Z3~Z5 T-60</p>	<p>差速器</p>  <p>內16T</p> <p>TCM FD180-200 T-61</p>	<p>變速箱</p>  <p>內19T</p> <p>TCM FD200 T-62</p>
<p>變速箱</p>  <p>內20T</p> <p>32434-30520-71 TOYOTA 7FD35-A50 H:62.5MM T-63</p>	<p>差速器</p>  <p>內18T</p> <p>TCM FD100 Z8 T-64</p>	<p>變速箱</p>  <p>25T</p> <p>33221-GE00A NISSAN 1F1 1F2 QD32 H:114MM T-65</p>	<p>差速器</p>  <p>總高 107MM 22T 121MM</p> <p>38211-GG30A NISSAN 1F1 1F2 QD32 H:107MM T-65-1</p>
<p>變速箱</p>  <p>17T</p> <p>12N53-82201 TCM FD15-35 C3/T3 T-66</p>	<p>變速箱</p>  <p>17T</p> <p>12N53-82631 TCM FD15-35 T3A T-67</p>	<p>變速箱</p>  <p>內10T</p> <p>32301-33901-71 TOYOTA 5FD50-80 T-68</p>	<p>變速箱</p>  <p>內20T</p> <p>16422-52461W TCM FD100-160S-3 T-69</p>



SPECIAL PURPOSE VEHICLE

<p>PULLEY COUPLING 《風扇皮帶盤》 《邦浦皮帶盤》</p>	<p>TRIANGLE BELT (三角式) BEARING 6308×2</p>  <p>40MM 2溝</p> <p>224W2-12712 TCM FD40 Z-7 (13×18T)(下) OD : 111MM H : 100.5MM UJ-5001</p>	<p>RIBBED BELT (時規式)</p>  <p>40MM 4溝</p> <p>224W2-12811 TCM FD40 Z-7 4PK (下) OD : 111MM H : 101MM UJ-5002</p>	<p>COUPLING (傳動軸皮帶盤接頭座)</p>  <p>107MM</p> <p>224W7-22021 TCM FD40 Z-7 UJ-5003</p>
<p>SHAFT JOINT</p>  <p>224W2-12061 TCM FD40 Z-7 內18T×13T 外28T UJ-5004</p>	<p>RIBBED BELT (時規式)</p>  <p>224W2-12062 TCM FD40 Z-7 內28T UJ-5005</p>	<p>TRIANGLE BELT (三角式) BEARING 6008×2</p>  <p>13T</p> <p>16211-32881-71 TOYOTA 5/6/7FD40 (下) OD : 109.5MM H : 59.5MM UJ-5006</p>	<p>UPPER TRIANGLE BELT (上三角式) V型溝</p>  <p>Φ15MM</p> <p>16301-32880-71 TOYOTA 5FD40 OD : 95MM UJ-5006A</p>
<p>RIBBED BELT (時規式)</p>  <p>13T 42T</p> <p>16211-32880-71 TOYOTA 5FD40 (下) OD : 105MM H : 82MM UJ-5007</p>	<p>COUPLING (傳動軸皮帶盤接頭座)</p>  <p>88MM 131MM 140MM</p> <p>235C7-22011 TCM FD40 Z-8 UJ-5010</p>	<p>COUPLING (傳動軸皮帶盤接頭座)</p>  <p>88MM 136MM 140MM</p> <p>243C7-22001 TCM FD40 T9 UJ-5017</p>	<p>SHAFT FAN (風扇座)</p>  <p>小芯 15MM</p> <p>16313-32880-71 TOYOTA 5FD40 (88-90) UJ-5012</p>
<p>SHAFT FAN (風扇座)</p>  <p>大芯 20MM</p> <p>16313-32882-71 TOYOTA 5FD40 (90-94) UJ-5013</p>	<p>(上風葉皮帶盤)</p>  <p>大芯10MM</p> <p>TOYOTA 5FD40 (尾批車) OD : 91.5MM UJ-5013A</p>	<p>TCM FD35 CORE AXIS TC-901</p>  <p>TC-901</p>	<p>PULLEY (發電機皮帶盤)</p>  <p>YM129930-77810 KOMATSU FD25 12/14/15S OD : 69MM H : 19MM UJ-5019</p>
<p>PULLEY (上風葉)</p>  <p>91301-04600 MITSUBISHI FD25 (S4S/S4E) OD : 82.5MM UJ-5020</p>	<p>PULLEY TENSION (下風葉)</p>  <p>91201-29600 MITSUBISHI FD25 S4S/S6S OD : 70MM UJ-5020-1</p>	<p>PULLEY TENSION</p>  <p>MITSUBISHI FD40 S6S/S6E OD : 90.5MM UJ-5020-2</p>	<p>FAN PULLEY (風扇皮帶盤)</p>  <p>Φ32 4分溝</p> <p>Z-5-13641-045-3 TCM FD25 (C240) OD : 101MM H : 54MM UJ-5021</p>



SPECIAL PURPOSE VEHICLE

<p>PULLEY COUPLING 《風扇皮帶盤》 《邦浦皮帶盤》</p>	<p>FAN PULLEY (風扇皮帶盤)</p>  <p>16371-78300-71 TOYOTA 5/6FD25 (1Z/2Z) OD : 142.5MM H : 49MM UJ-5023</p>	<p>FAN PULLEY (風扇皮帶盤)</p>  <p>Z-8-94149-359-1 TCM FD25 4JG2 OD : 130MM H : 59MM UJ-5024</p>	<p>FAN PULLEY (風扇皮帶盤)</p>  <p>16371-78703-71 TOYOTA 7/8FD25 (2Z/3Z/1DZ) OD : 143MM UJ-5032</p>
<p>FAN PULLEY (風扇皮帶盤)</p>  <p>16371-76023-71 - 6FD40 16372-42500-71 - 7FD40 TOYOTA 5/6/7FD40 (1DZ) OD : 121MM H : 50MM UJ-5038</p>	<p>PULLEY (下風扇皮帶調整盤)</p>  <p>MITSUBISHI FD40 (S6S) 35×70MM UJ-5043</p>	<p>PULLEY (上風扇皮帶調整盤)</p>  <p>23150-43G0C MITSUBISHI FD40 (S6S) NISSAN TD27 2.5T 47×80MM UJ-5044</p>	<p>WATER PUMP PULLEY (水邦浦 / 風扇皮帶盤)</p>  <p>32A45-02100 MITSUBISHI F18B S4S H-43MM OD : 119MM UJ-5054</p>
<p>WATER PUMP PULLEY (水邦浦 / 風扇皮帶盤)</p>  <p>32A45-03400 MITSUBISHI F18C/F14E S4S OD : 138MM UJ-5054-1</p>	<p>RIBBED BELT (時規式 7PK)</p>  <p>16377-30510-71 (前批) TOYOTA 7FD40/50 (14Z) OD : 104.5MM UJ-5055</p>	<p>RIBBED BELT (時規式 7PK)</p>  <p>16378-30510-71 (後批) TOYOTA 7FD40/50 (14Z) OD : 97MM UJ-5055-1</p>	<p>RIBBED BELT (時規式 7PK)</p>  <p>16373-30520-71 TOYOTA 7FG40 (1FZ) OD : 77MM UJ-5055-2</p>
<p>FAN PULLEY (風扇皮帶盤)</p>  <p>32B45-04100 TCM 4T (T-9) (S6S) MITSUBISHI 4T (S6S) OD : 143MM H : 71.5MM UJ-5060</p>	<p>FAN PULLEY (風扇皮帶盤)</p>  <p>32B45-02200 早批車(小面) TCM 4T (T-9) (S6S) OD : 115MM H : 70MM UJ-5060-1</p>	<p>FAN PULLEY (風扇皮帶盤)</p>  <p>MITSUBISHI S6S F28B 4-5T EF19B/28A FD35-50 OD : 100MM H : 74.5MM UJ-5060-2</p>	<p>FAN PULLEY (風扇皮帶盤)</p>  <p>32B45-02101 MITSUBISHI S6S OD : 125MM UJ-5060-3</p>
<p>FAN PULLEY (風扇皮帶調整輪)</p>  <p>TCM FD40/45 T-9 (S6S) MITSUBISHI 4T (S6S) 25×82MM UJ-5061</p>	<p>FAN PULLEY (風扇皮帶盤)</p>  <p>TCM FD25/30 (4BC2) OD : 146MM H : 55MM UJ-5063</p>	<p>GENERATOR PULLEY (發電機風扇皮帶盤)</p>  <p>A-21051-44G00 NISSAN TD27 QD32 (雙溝) OD : 130MM H : 62.5MM UJ-5064</p>	<p>FAN PULLEY (風扇皮帶盤)</p>  <p>BN-1K011-74250 TCM FD25/30 T6H (V3300) OD : 133MM H : 58MM UJ-5070</p>



SPECIAL PURPOSE VEHICLE

<h3>PULLEY COUPLING</h3> <p>《風扇皮帶盤》 《邦浦皮帶盤》</p>	<p>HOUSING (皮帶盤軸支撐座)</p>  <p>16314-32882-71 TOYOTA 7FD40</p> <p>UJ-5071</p>	<p>FAN PULLEY (風扇皮帶盤)</p>  <p>$\Phi 32$</p> <p>Z-1-13641-165-0 TCM FD40-60 (6BB1) OD : 154MM (雙溝) (小) H : 72MM</p> <p>UJ-5078</p>	<p>FAN PULLEY (風扇皮帶盤)</p>  <p>$\Phi 32$</p> <p>TCM FD40-60 (6BG1) OD : 174.5MM (雙溝) (大) H : 73MM</p> <p>UJ-5079</p>
<p>TRIANGLE BELT (三角式)</p>  <p>108.5 MM</p> <p>16371-32872-71 (前批) TOYOTA 7FD40-50 14Z OD : 75.4MM</p> <p>UJ-5080</p>	<p>TRIANGLE BELT (三角式)</p>  <p>108.5 MM</p> <p>16371-32881-1 (後批) TOYOTA 7FD40-A50 13/14Z ----- 5FD40 11Z OD : 91.4MM</p> <p>UJ-5080-1</p>	<p>TRIANGLE BELT (三角式)</p>  <p>108.5 MM</p> <p>16371-30510-71 TOYOTA 7FD35 ----- 7FDK40 13/14Z OD : 99.5MM</p> <p>UJ-5080-2</p>	<p>FAN PULLEY (風扇皮帶盤)</p>  <p>$\Phi 30$</p> <p>224W2-12702 TCM FD40 Z-7 (小) (雙溝) OD : 99MM H : 50MM</p> <p>UJ-5084</p>
<p>WATER PUMP PULLEY (水邦浦 / 風扇皮帶盤)</p>  <p>$\Phi 36$</p> <p>KOMATSU FD25 11S (4D95) OD : 150MM H : 54MM</p> <p>UJ-5087</p>	<p>WATER PUMP PULLEY (水邦浦 / 風扇皮帶盤)</p>  <p>$\Phi 28.6$</p> <p>129900-42450 KOMATSU 12/14/15/16/17S FD25 (4D94E) H : 47.5MM OD : 121MM</p> <p>UJ-5088</p>	<p>FAN PULLEY (風扇皮帶盤)</p>  <p>$\Phi 28.6$</p> <p>16371-78151-71 TOYOTA 7/8FG25 (4Y) (大) OD : 129MM H : 53MM</p> <p>UJ-5089</p>	<p>FAN PULLEY (風扇皮帶盤)</p>  <p>$\Phi 28.6$</p> <p>16371-78204-71 TOYOTA 7/8FD10-30 ----- 1DZ(Ⅱ/Ⅲ) / 2Z / 3Z OD : 130MM H : 62.5MM</p> <p>UJ-5090</p>
<p>FAN PULLEY (風扇皮帶盤)</p>  <p>$\Phi 28.6$</p> <p>129900-42461 KOMATSU FD25 16S (4TNE98) YALE/YANMAR TAILIFT (NEW) UJ-5091</p> <p>OD : 110MM H : 48MM</p>	<p>FAN PULLEY (風扇皮帶盤)</p>  <p>$\Phi 24.5$</p> <p>16371-78101-71 TOYOTA 5FG 2J OD : 98MM H : 51MM</p> <p>UJ-5092</p>	<p>PULLEY (邦浦皮帶盤)</p>  <p>40MM 7溝 101.5 MM</p> <p>16281-36761-71 TOYOTA 8FD35-50 (7PK) OD : 115MM</p> <p>UJ-5093</p>	<p>PULLEY (邦浦皮帶盤)</p>  <p>40MM 7溝 101.5 MM</p> <p>16281-36880-71 TOYOTA 8FD35-50 (7PK) OD : 94MM</p> <p>UJ-5094</p>
<p>FAN PULLEY (風扇皮帶盤)</p>  <p>130 MM 7溝</p> <p>16171-36762-71 TOYOTA 8FD35-80 OD : 101MM</p> <p>UJ-5095</p>	<p>PLATE COUPLING (風扇固定片)</p>  <p>15T</p> <p>16315-36761-71 TOYOTA 8FD35-80 內15T OD : 72MM</p> <p>UJ-5095-1</p>	<p>HOUSING (風扇皮帶盤固定座) W/O BEARING</p>  <p>16314-N3170-71 TOYOTA 8FD35-80 UJ-5095-2</p>	<p>FAN PULLEY (風扇皮帶盤)</p>  <p>130 MM 7溝</p> <p>16172-36762-71 TOYOTA 8FD35-80 OD : 93MM</p> <p>UJ-5095-3</p>



SPECIAL PURPOSE VEHICLE

<p>PULLEY COUPLING 《風扇皮帶盤》 《邦浦皮帶盤》</p>	<p>FAN PULLEY (風扇皮帶盤)</p>  <p>16174-36762-71 TOYOTA 8FD35-80 OD : 88MM UJ-5095-4</p>	<p>PLATE COUPLING (風扇固定片)</p>  <p>16315-36880-71 TOYOTA 8FD35-80N 內15T OD : 72MM UJ-5095-5</p>	<p>FAN PULLEY (風扇皮帶盤)</p>  <p>16173-36762-71 TOYOTA 8FD35-80 OD : 95MM UJ-5095-6</p>
<p>PULLEY (液壓邦浦皮帶盤)</p>  <p>93701-00401 MITSUBISHI 4-5T S6S F19C OD : 130MM H : 63MM UJ-5104</p>	<p>BOLT & NUT</p>  <p>MITSUBISHI S4S/S6S 91801-12800 錐套 UJ-5104-1 91801-00800 螺母 UJ-5104-2 錐套+螺母 UJ-5104-3</p>	<p>FAN PULLEY (風扇皮帶盤)</p>  <p>16371-78206-71 TOYOTA 8FD10-30 1DZ/2Z OD : 161MM H : 63MM UJ-5108</p>	<p>FAN PULLEY (風扇皮帶盤)</p>  <p>6206-61-3240 KOMATSU FD40-60 6D95 OD : 138MM H : 53MM UJ-5111</p>
<p>PULLEY (液壓邦浦皮帶輪)</p>  <p>91402-01100 MITSUBISHI S4S F18B F14C OD : 90MM H : 32.5MM UJ-5112</p>	<p>HOUSING (風扇皮帶輪固定座)</p>  <p>91802-13300 MITSUBISHI S6S F19C F28B OD : 130MM H : 78MM UJ-5113</p>	<p>PULLEY (液壓邦浦皮帶輪)</p>  <p>91301-10600 MITSUBISHI S4E OD : 82.5MM H : 32MM UJ-5120</p>	<p>BOLT & NUT</p>  <p>MITSUBISHI S4E 91201-07500 錐套 UJ-5120-1 91201-10700 螺母 UJ-5120-2 錐套+螺母 UJ-5120-3</p>
<p>FAN PULLEY (風扇皮帶盤)</p>  <p>6207-61-3251 KOMATSU FD35-50A ----- 4D95L OD : 151.5MM H : 53MM UJ-5126</p>	<p>FAN PULLEY (風扇皮帶盤)</p>  <p>32B45-12500 MITSUBISHI S6S 6-7T OD : 118MM UJ-5127</p>	<p>SPACER,FAN (風扇固定鋁座)</p>  <p>6206-61-3850 KOMATSU FD35-50A 10S OD : 109.5MM H : 55MM UJ-5128</p>	



SPECIAL PURPOSE VEHICLE

<p>PULLEY COUPLING 《曲軸皮帶盤》</p>	<p><u>CRANKSHAFT PULLEY</u> (曲軸皮帶盤)</p>  <p>13471-78200 / 78201-71 TOYOTA 5/6FD25/30 (1DZ) OD : 144MM H : 56MM UJ-5018</p>	<p><u>CRANKSHAFT PULLEY</u> (曲軸皮帶盤)</p>  <p>Z-8-94470-551-0 TCM FD25 (C240) OD : 137MM H : 56MM UJ-5022</p>	<p><u>CRANKSHAFT PULLEY</u> (曲軸皮帶盤)</p>  <p>Z-9-12370-807-1 TCM FD25 (C240-PJK) OD : 139MM H : 52.5MM UJ-5022-1</p>
<p><u>CRANKSHAFT PULLEY</u> (曲軸皮帶盤)</p>  <p>13471-78300-71 TOYOTA 5FD25 (1Z) OD : 144MM H : 51.5MM UJ-5029</p>	<p><u>CRANKSHAFT PULLEY</u> (曲軸皮帶盤)</p>  <p>13471-78701-71 TOYOTA 6/7FD25 (2Z) OD : 144MM H : 56.5MM UJ-5030</p>	<p><u>CRANKSHAFT PULLEY</u> (曲軸皮帶盤)</p>  <p>13471-78330-71 TOYOTA 5~7FD40 11Z/13Z OD : 175MM H : 51.5MM UJ-5031</p>	<p><u>CRANKSHAFT PULLEY</u> (曲軸皮帶盤)</p>  <p>12304-41K01 NISSAN TD27/QD32 (3溝) OD : 148MM H : 82MM UJ-5037</p>
<p><u>CRANKSHAFT PULLEY</u> (曲軸皮帶盤)</p>  <p>13471-78205-71 TOYOTA 7/8FD10~30 (1DZ) OD : 144MM H : 64.5MM UJ-5039</p>	<p><u>CRANKSHAFT PULLEY</u> (曲軸皮帶盤)</p>  <p>13471-78157-71 TOYOTA 6-8FG 1-3T 4Y/5K (自排) OD : 133MM H : 42.5MM UJ-5040</p>	<p><u>CRANKSHAFT PULLEY</u> (曲軸皮帶盤)</p>  <p>13471-78703-71 TOYOTA 7FD/8FD25 (2Z) OD : 144MM H : 64MM UJ-5042</p>	<p><u>CRANKSHAFT PULLEY</u> (曲軸皮帶盤)</p>  <p>Z-8-97128-397-1 TCM FD25 (4JG2) OD : 145MM H : 55.5MM UJ-5045</p>
<p><u>RIBBED BELT</u> (時規式)</p>  <p>16211-30610 TOYOTA 7FD40 7PK(7溝) OD : 115MM H : 74MM UJ-5046</p>	<p><u>CRANKSHAFT PULLEY</u> (曲軸皮帶盤)</p>  <p>KOMATSU FD25 11S (4D95) OD : 151MM H : 53MM UJ-5052</p>	<p><u>CRANKSHAFT PULLEY</u> (曲軸皮帶盤)</p>  <p>YM129900-21660 KOMATSU 12/15/16S (4D94E) OD : 130MM H : 57MM UJ-5053</p>	<p><u>CRANKSHAFT PULLEY</u> (曲軸皮帶盤)</p>  <p>Z-1-12371-364-1 TCM 4T Z-7 (6BB1) (雙溝) OD : 169MM H : 96MM UJ-5056</p>
<p><u>CRANKSHAFT PULLEY</u> (曲軸皮帶盤)</p>  <p>32B20-01501 TCM 4T T-9 (S6S) OD : 150MM H : 92MM UJ-5062</p>	<p><u>CRANKSHAFT PULLEY</u> (曲軸皮帶盤)</p>  <p>TOYOTA (2J) OD : 147MM H : 62.5MM UJ-5066</p>	<p><u>CRANKSHAFT PULLEY</u> (曲軸皮帶盤)</p>  <p>13471-78155-71 TOYOTA 5/6FG20~25 (4Y/5K) OD : 133MM H : 45MM UJ-5067</p>	<p><u>CRANKSHAFT PULLEY</u> (曲軸皮帶盤)</p>  <p>13471-78D00-71 TOYOTA 7FD40 (14Z/15Z) OD : 175MM H : 51.5MM UJ-5069</p>



SPECIAL PURPOSE VEHICLE

<p>PULLEY COUPLING 《曲軸皮帶盤》</p>	<p><u>CRANKSHAFT PULLEY</u> (曲軸皮帶盤)</p>  <p>32A20-02101 MITSUBISHI S4S 14C/18B ----- 2.5T-3.5T OD : 162MM H : 60.5MM UJ-5096</p>	<p><u>CRANKSHAFT PULLEY</u> (曲軸皮帶盤)</p>  <p>13471-78640-71 TOYOTA 7FG40 1FZ OD : 177MM H : 72.5MM UJ-5097</p>	<p><u>CRANKSHAFT PULLEY</u> (曲軸皮帶盤)</p>  <p>32A20-02203 MITSUBISHI S6S ---- FD40K-FD50K FD60-70 ---- F19C F28B F20C F20B 內4孔 M8x1.25 外6孔 M10x1.25 UJ-5098</p> <p>OD : 162MM H : 69MM</p>
<p><u>CRANKSHAFT PULLEY</u> (曲軸皮帶盤)</p>  <p>OD : 162MM H : 69MM</p> <p>32B20-01302 MITSUBISHI S6S ---- FD40K-FD50K FD60-70 ---- F19C F28B F20C F20B 內4孔 M8x1.25 外6孔 M8x1.25 UJ-5098-1</p>	<p><u>CRANKSHAFT PULLEY</u> (曲軸皮帶盤)</p>  <p>13471-78C02-71 TOYOTA 8FD25 3Z OD : 170MM H : 64MM UJ-5099</p>	<p><u>CRANKSHAFT PULLEY</u> (曲軸皮帶盤)</p>  <p>OD : 150MM H : 92MM</p> <p>32A20-03400 (OLD) MITSUBISHI S4S F18C 4孔固定孔 UJ-5100</p>	<p><u>CRANKSHAFT PULLEY</u> (曲軸皮帶盤)</p>  <p>OD : 150MM H : 92MM</p> <p>32A20-03600 (NEW) MITSUBISHI S4S F18C 無固定孔 UJ-5101</p>
<p><u>CRANKSHAFT PULLEY</u> (曲軸皮帶盤)</p>  <p>12305-L9061 NISSAN TD42 4-6T OD : 175MM H : 126MM UJ-5106</p>	<p><u>CRANKSHAFT PULLEY</u> (曲軸皮帶盤)</p>  <p>1C010-74282 KUBOTA V3300 內20T OD : 143MM H : 51MM UJ-5107</p>	<p><u>CRANKSHAFT PULLEY</u> (曲軸皮帶盤)</p>  <p>32C20-05100 (NEW) MITSUBISHI FD10-20 S4Q2 OD : 145MM H : 91.5MM UJ-5109</p>	<p><u>CRANKSHAFT PULLEY</u> (曲軸皮帶盤)</p>  <p>12305-L9061 (OLD) MITSUBISHI FD10-20 S4Q2 OD : 155MM H : 78MM UJ-5109-1</p>
<p><u>CRANKSHAFT PULLEY</u> (曲軸皮帶盤)</p>  <p>13471-UK010 TOYOTA 8FG35-80 1FS OD : 144MM H : 51MM UJ-5110</p>	<p><u>CRANKSHAFT PULLEY</u> (曲軸皮帶盤)</p>  <p>6271-31-1430 KOMATSU FD40 10S ----- 4D95LE-5 OD : 150MM H : 86MM UJ-5114</p>	<p><u>CRANKSHAFT PULLEY</u> (曲軸皮帶盤)</p>  <p>32B20-11292 MITSUBISHI S6S (雙溝) OD : 162MM H : 92.5MM UJ-5119</p>	<p><u>CRANKSHAFT PULLEY</u> (曲軸皮帶盤)</p>  <p>YM129907-21650 YANMAR 4TNE98 OD : 130MM H : 64MM UJ-5121</p>
<p><u>CRANKSHAFT PULLEY</u> (曲軸皮帶盤)</p>  <p>YM129907-21660 YANMAR 4TEN92/4TNV94 OD : 130MM H : 66MM UJ-5122</p>	<p><u>CRANKSHAFT PULLEY</u> (曲軸皮帶盤)</p>  <p>13471-UM010 TOYOTA 8FD20-J35 1ZS OD : 166MM H : 69.5MM UJ-5123</p>		